

KESİT S-S
ÖLÇEK 1 : 1

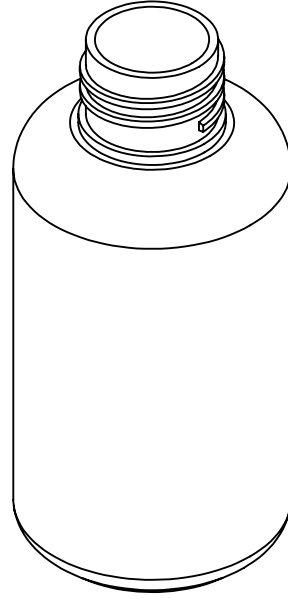
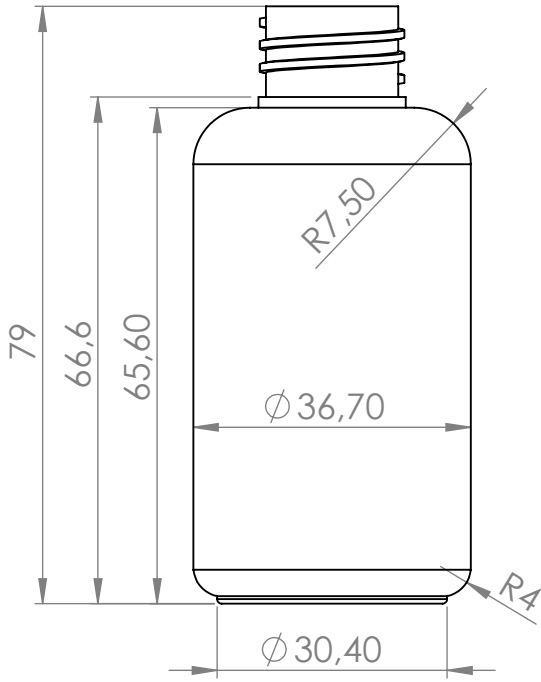

AKSİ BELİRTİLMEDİĞİ SÜRECE: BOYUTLAR MİLMETREDİR YÜZEY CİLASI: TOLERANS: +/- 0.5mm DOĞRUSAL: AÇISAL:		BİTİRME: 11.12.2015		KESKİN KENARLARI PAHLAYIN VE KIRIN		TEKNİK RESMİ ÖLÇEKLENDİRME		REVİZYON	
						50 ml. Şişe			
İSİM		İMZA		TARİH		BAŞLIK:			
ÇİZEN AHMET ÖZKAYA				11.12.2015		ŞEN-PA PLASTİK EŞYA KALIP İMALATI SAN. TİC. LTD. ŞTİ			
ONAY. SELİM OĞUZLU				11.12.2015					
ÜRET. CEMİL UÇAN				11.12.2015					
KALİTE ŞAFAK VARLI				11.12.2015					
MALZEME:						RESİM NO.		A4	
HDPE						180			
AĞIRLIK: 9,7 gr +/- 0,5						ÖLÇEK: 1/1		SAYFA : 1/1	