

KESIT I-I

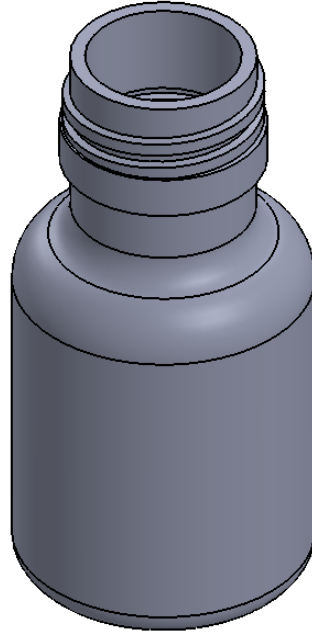
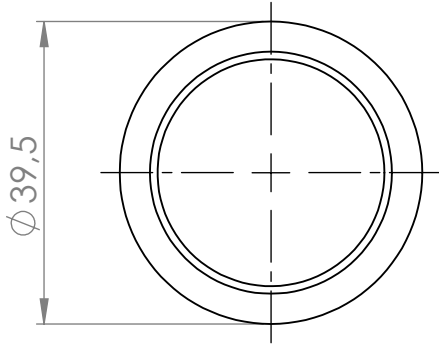

AKSİ BELİRTİLMEDİĞİ SÜRECE:
BOYUTLAR MİLMETREDİR
YÜZEY CİLASI:
TOLERANS: +/- 0.5mm
DOĞRUSAL:
AÇISAL:

BİTİRME:

23.05.2017

KESKİN KENARLARI
PAHLAYIN VE
KIRIN

TEKNİK RESMİ ÖLÇEKLENDİRME

REVİZYON

45 ml ŞİŞE

	İSİM	İMZA	TARİH		
ÇİZEN	AHMET ÖZKAYA		23.05.2017		
ONAY.	SELİM OĞUZLU		23.05.2017		
ÜRET.	ÖMER KADIOĞLU		23.05.2017		
KALİTE	AYCAN AKGÜL		23.05.2017		

BAŞLIK:

SEN-PA PLASTİK EŞYA KALIP
İMALATI SAN. TİC. LTD. ŞTİ

MALZEME:

HDPE

RESİM NO.

508

A4

AĞIRLIK: 13 gr. +/- 0.5

ÖLÇEK: 1/1

SAYFA : 1/1