

DETAY O  
ÖLÇEK 1 : 1

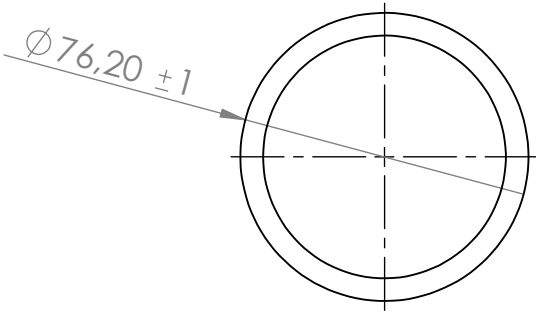

AKSİ BELİRTİLMEDİĞİ SÜRECE: BOYUTLAR MİLMETREDİR YÜZEY CILASI: TOLERANS: +/- 0.5mm DOĞRUSAL: AÇISAL:		BİTİRME: <b>08.03.2018</b>		KESKİN KENARLARI PAHLAYIN VE KIRIN		TEKNİK RESMİ ÖLÇEKLENDİRME		REVİZYON	
						<b>350 ml Şişe</b>			
İSİM		İMZA		TARİH		BAŞLIK:			
ÇİZEN AHMET ÖZKAYA				08.03.2018		<b>ŞEN-PA PLASTİK EŞYA KALIP İMALATI SAN. TİC. LTD. ŞTİ</b>			
ONAY. SELİM OĞUZLU				08.03.2018					
ÜRET. CEMİL UÇAN				08.03.2018					
KALİTE ŞAFAK VARLI				08.03.2018					
MALZEME: <b>HDPE</b>						RESİM NO. <b>515</b>		A4	
SİLME HACMİ: 380 ml +/- 10 ml				AĞIRLIK: 30.5 gr +/- 1 gr		ÖLÇEK: 1/2		SAYFA: 1/1	