

KESİT P-P
ÖLÇEK 1 : 1

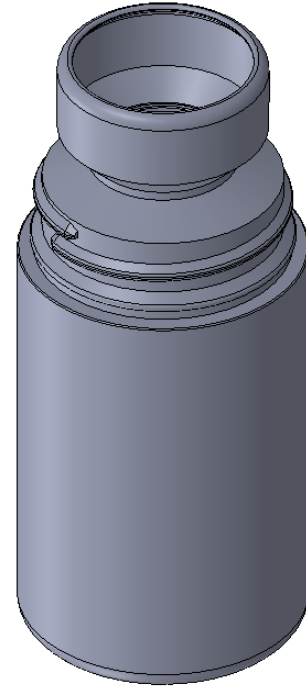
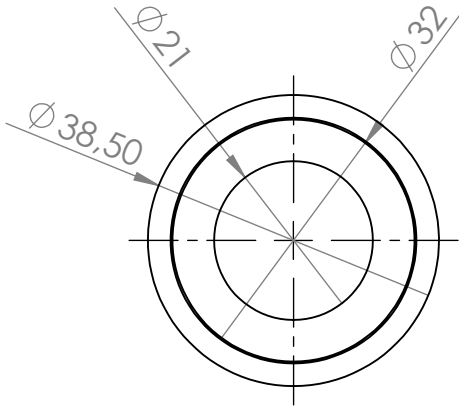

AKSİ BELİRTİLMEDİĞİ SÜRECE:
BOYUTLAR MİLMETREDİR
YÜZEY CİLASI:
TOLERANS: +/- 0.5mm
DOĞRUSAL:
AÇISAL:

BİTİRME:

12.03.2018

KESKİN KENARLARI
PAHLAYIN VE
KIRIN

TEKNİK RESMİ ÖLÇEKLENDİRME

REVİZYON

50 ml. Roll On Şişe R

| İSİM | İMZA | TARİH |
|--------|--------------|------------|
| ÇİZEN | AHMET ÖZKAYA | 12.03.2018 |
| ONAY. | SELİM OĞUZLU | 12.03.2018 |
| ÜRET. | CEMİL UÇAN | 12.03.2018 |
| KALİTE | ŞAFAK VARLI | 12.03.2018 |

BAŞLIK:

ŞEN-PA PLASTİK EŞYA KALIP
İMALATI SAN. TİC. LTD. ŞTİ

MALZEME:

HDPE

RESİM NO.

527

A4

AĞIRLIK: 10.2 gr +/- 0.5

ÖLÇEK: 1/1

SAYFA : 1/1