

KESIT O-O

DETAY P
ÖLÇEK 3 : 1

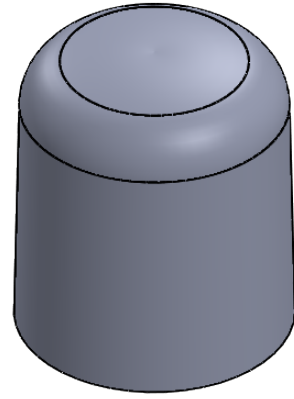
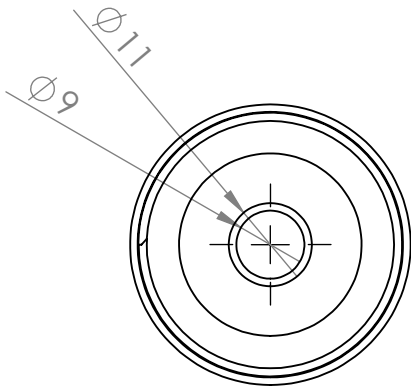

AKSİ BELİRTİLMEDİĞİ SÜRECE:
BOYUTLAR MİLİMETREDİR
YÜZEY CILASI:
TOLERANS: +/- 0.5mm
DOĞRUSAL:
AÇISAL:

BİTİRME:

09.03.2018

KESKİN KENARLARI
PAHLAYIN VE
KIRIN

TEKNİK RESMİ ÖLÇEKLENDİRME

REVİZYON

50 ml. Roll On Şişe Kapağı R

İSİM	İMZA	TARİH
ÇİZEN	AHMET ÖZKAYA	09.03.2018
ONAY.	SELİM OĞUZLU	09.03.2018
ÜRET.	CEMİL UÇAN	09.03.2018
KALİTE	ŞAFAK VARLI	09.03.2018

BAŞLIK:

ŞEN-PA PLASTİK EŞYA KALIP
İMALATI SAN. TİC. LTD. ŞTİ

MALZEME:

PP

RESİM NO.

528

A4

AĞIRLIK: 7.35 gr +/- 0.5

ÖLÇEK: 1/1

SAYFA : 1/1