

KESİT Q-Q

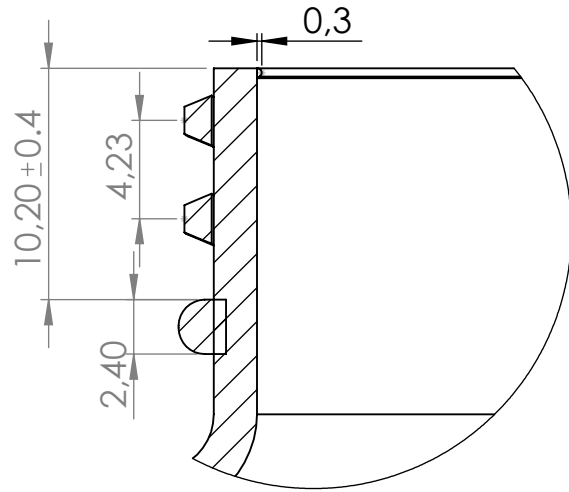
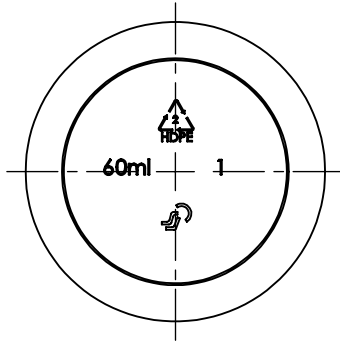

DETAY R
ÖLÇEK 3 : 1

AKSİ BELİRTİLMEDİĞİ SÜRECE:
BOYUTLAR MİLMETREDİR
YÜZEY CİLASI:
TOLERANS: +/- 0.5mm
DOĞRUSAL:
AÇISAL:

BITİRME:

06.04.2018

KESKİN KENARLARI
PAHLAYIN VE
KIRIN

TEKNİK RESMİ ÖLÇEKLENDİRME

REVİZYON

60 ml. 32x20 Şişe

İSİM	İMZA	TARİH
ÇİZEN	AHMET ÖZKAYA	06.04.2018
ONAY.	SELİM OĞUZLU	06.04.2018
ÜRET.	CEMİL UÇAN	06.04.2018
KALİTE	ŞAFAK VARLI	06.04.2018

BAŞLIK:

SEN-PA PLASTİK EŞYA KALIP
İMALATI SAN. TİC. LTD. ŞTİ

MALZEME:

HDPE

RESİM NO.

531

A4

SİLME HACMİ :

62 +/- 3.5ml

AĞIRLIK:

18 +/- 1gr

ÖLÇEK:

1/1

SAYFA :

1/1