

KESIT R-R

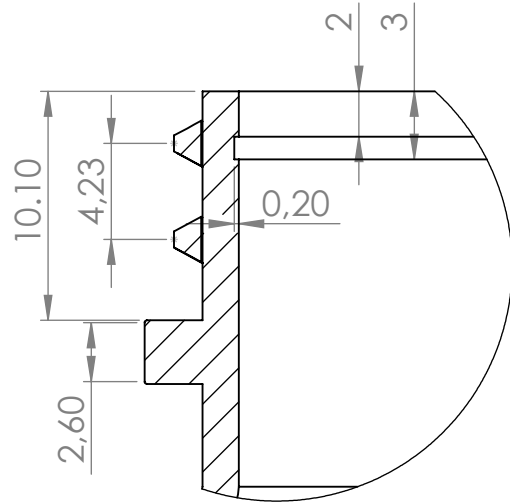
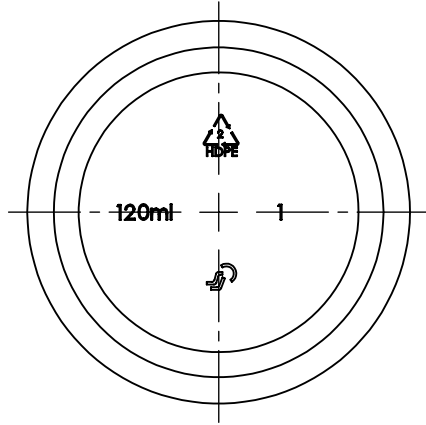

DETAY S  
ÖLÇEK 3 : 1

UNLESS OTHERWISE SPECIFIED:  
DIMENSIONS ARE IN MILLIMETERS  
SURFACE FINISH:  
TOLERANCES: +/- 0.5mm  
LINEAR:  
ANGULAR:

FINISH:

06.04.2018

DEBUR AND  
BREAK SHARP  
EDGES

DO NOT SCALE DRAWING

REVISION

120 ml. 38x20 Bottle

	NAME	SIGNATURE	DATE
DRAWN	AHMET ÖZKAYA		06.04.2018
CONF.	SELİM OĞUZLU		06.04.2018
PROD.	CEMİL UÇAN		06.04.2018
QUA.	ŞAFAK VARLI		06.04.2018

MATERIAL:

HDPE

DWG NO.

533

A4

FULL VOLUME: 136 ml. +/- 0.5

WEIGHT: 14.3 gr +/- 0.5 gr

SCALE: 1/1

PAGES: 1/1

SEN-PA PLASTİK EŞYA KALIP  
İMALATI SAN. TİC. LTD. ŞTİ